

# Access and Interconnection Agreement

Sub Annex C-FA 10 Wholesale Terminating Segments of  
Leased Lines

20

IAK  
AEP MZ L.B YZ

Access and Interconnection Agreement – Omantel – Ooredoo

Sub Annex C-FA 10 \_ Wholesale Terminating Segment of Leased Line

## Table of Contents

1	General.....	3
2	Definitions.....	4
3	Termination Segment of Leased Lines Services.....	5
4	Terms and Conditions .....	7
5	Database .....	10
6	Ordering and Delivery.....	11
7	Prices .....	12
8	Fault Management.....	13
9	Forecasts .....	14

IAK  
Acep Mz L.B 42

Access and Interconnection Agreement – Omantel – Ooredoo

Sub Annex C-FA 10 \_ Wholesale Terminating Segment of Leased Line

## 1 General

- 1.1 This Sub Annex sets out the Omantel offer for Terminating Segment of Leased Lines.
- 1.2 Omantel through this access Services enable the Requesting Party to access Customer's location through Omantel's existing copper connectivity to the Customer premises.
- 1.3 Terminating Segment of Leased Lines requested in remote areas, outside exchange areas or outside present coverage area will be provided on specific conditions.

AK

AK Mz L.B 42

Page 3 of 14

Access and Interconnection Agreement – Omantel – Ooredoo

Sub Annex C-FA 10 \_ Wholesale Terminating Segment of Leased Line

## 2 Definitions

2.1 The definitions in Annex L shall apply to this Sub Annex in addition to the following definitions:

2.1.1 Trunk Node – Omantel Equipment in Omantel Exchange

2.1.2 Contract Term – the contract period of the Services provisioning starting from the Services provisioning date.

IAK

AK Mz L.B 42

### 3 Termination Segment of Leased Lines Services

3.1 Omantel offers the Requesting Party the possibility to access the Customer premises using Omantel existing copper connectivity to the Customer premises.

3.2 The Termination Segment of Leased Lines can be offered in two ways:

- (a) Direct connection from the Trunk Node to which the Customer have a direction connection to the Requesting Party Point of Access.

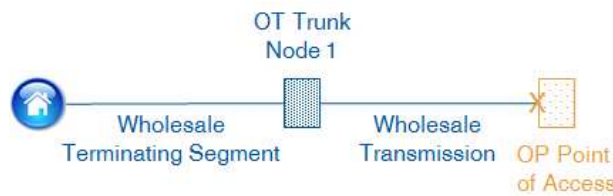

Figure 3-1 Termination Segment of Leased Line (Direct connection)

- (b) Via a Trunk Segment of a Leased Line in case the Requesting Party Access Point is not directly connected to Omantel Trunk Node to which the Customer is connected.

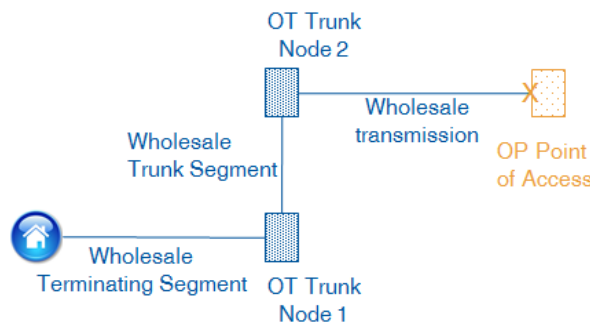

Figure 3-2 Termination Segment of Leased Line (Via a Trunk Segment)

3.3 The Requesting Party shall also request a Wholesale Transmission which will facilitate the connectivity between the Requesting Party and Omantel.

3.4 The Termination Segment of Leased Lines portfolio consists of the following bandwidths

- (c) 2 Mbit/s

IAK

Aly Mz L.B 42

Access and Interconnection Agreement – Omantel – Ooredoo

Sub Annex C-FA 10 \_ Wholesale Terminating Segment of Leased Line

- (d) 34 Mbit/s
- (e) 155 Mbit/s
- (f) 1 Gbits/s
- (g) 10 Gbits/s
- (h) 100 Gbits/s

3.5 Upon receiving the request, Omantel can provide other bandwidths on terms and conditions agreed between both parties and Omantel shall inform the TRA accordingly and obtain the necessary approvals from it. Such requests are handled according to Annex H.

IAK

AKP Mz L.B 42

## 4 Terms and Conditions

### 4.1 Services Provisioning:

- 4.1.1 The Service provision shall be subject to a technical feasibility study. If the result of the feasibility study is that the order shall be rejected, Omantel will justify that conclusion and share the reasons with the Requesting Party in writing..
- 4.1.2 The Service will be offered in locations only where Omantel has the end to end connectivity to the Customer's premises.
- 4.1.3 Omantel shall remain the owner of the Service. The Requesting Party shall not assign, transfer, lease, sell, or share their interest in the Service with any Third Party Operator.
- 4.1.4 Omantel will be responsible to maintain the Service and shall ensure that the Service offered to the Requesting Party are at the same level of quality as those to Omantel's own Customers.
- 4.1.5 Upon receiving the request, Omantel will check the technical feasibility to provide the Services to the Requesting Party.
- 4.1.6 Omantel shall not be responsible for any work within the boundary of the Customer premises.

### 4.2 The Requesting Party Responsibility:

- 4.2.1 The Requesting Party shall submit a copy of the Customer's application form duly completed and signed by the Customer for each Customer request. The request shall contain all necessary information about the Customer such as but not limited to the Customer details, the connectivity points and his connectivity requirement.

IAK

AK Mz L.B 42

- 4.2.2 The Requesting Party shall be responsible of the availability and quality of the Services offered to its Customer.
- 4.2.3 The Requesting Party shall be responsible to invoice and collect the outstanding dues from the Customers for the purpose of providing the Services.
- 4.2.4 The Requesting party shall be responsible of providing, monitoring and maintaining the CPE at Customer location.
- 4.2.5 The Requesting Party shall pay Omantel the charges specified in Clause 7 below even if the Customer has not paid his dues to the Requesting Party.
- 4.2.6 The Requesting Party shall be responsible towards the Services quality provided to the Customer in case the requested capacity on the core and access network is not correctly designed and requested by the Requesting Party from Omantel.
- 4.3 Requesting Party shall setup a call center to address all complaints from its Customers.
- 4.4 Change request to existing link.
- 4.4.1 Upgrading the bandwidth orders are placed according to order procedures in Clause 6 of this Sub Annex.
- 4.4.2 The monthly fees for the increased bandwidth will be applicable from the date that the upgrade is performed.
- 4.4.3 New Contract Terms will be applicable for the upgraded link and the existing Contract Terms will be cancelled without any early termination charges provided that the new Contract Terms at least covers the remaining period of the previous Contract.
- 4.4.4 Changes other than upgrading the bandwidth shall be considered as a termination of the Service and order of a new one. A downgrade of no more than 5% of the relevant capacity provided to the Requesting Party within the relevant minimum contract period shall be acceptable and shall not be treated as termination of the service. For the avoidance of doubt, a downgrade after the minimum contract period has expired shall not require a termination and reorder.

AK

AK Mz L.B 42

Access and Interconnection Agreement – Omantel – Ooredoo

Sub Annex C-FA 10 \_ Wholesale Terminating Segment of Leased Line

#### 4.5 Contract Terms and Termination:

4.5.1 The minimum Contract Term is one (1) Year.

4.5.2 After the completion of the Contract Term:

4.5.2.1 If either Party wishes to terminate the contract after the completion of the Contract Term, it shall inform the other party, in writing, one (1) month before the completion of Contract Term, of its intent to terminate the Contract. The Providing Party shall not terminate the Contract without the prior approval of the TRA.

4.5.2.2 If no notice is provided at least one (1) month before the completion of Contract, the Contract will be automatically renewed on monthly rolling basis.

4.5.2.3 Omantel has the right to suspend the Service in accordance with Clause 17 of the Main Agreement in case the Requesting Party is in breach of its obligation under this Agreement.

4.5.3 Termination of the Service by the Requesting Party before the expiration of the Contract Term is subject to early Termination Fee equal to the charges of the remaining period of the Contract Term. Once the initial term has concluded, and the agreement has been renewed, no Early Termination fees shall be applicable. If either Party wishes to terminate the contract, it shall inform the other party in writing one (1) month in advance of its intent to terminate the Contract. The Providing Party shall not terminate the Contract without the prior approval of the TRA.

4.5.4 The Requesting Party can terminate the contract upon the request from the Customer without the Termination Fee if the Customer requested the Service from Omantel directly or through any Third Party Operator.

4.5.5 The termination will be in accordance with the procedures in Annex H.

IAK

AK  
Mz L.B 42

Page 9 of 14

## 5 Database

5.1 Omantel will install and keep updated a database consisting of all active and ordered Terminating Segment of the Leased Line of the Requesting Party. The database will consist of at least the following parameters:

- (a) Customer Name
- (b) actual bandwidth
- (c) former bandwidth(s)
- (d) Customer address
- (e) order date
- (f) agreed and promised delivery date
- (g) actual delivery date
- (h) reported faults
- (i) maintenance actions taken
- (j) installation fee
- (k) monthly fee
- (l) discount schemes applicable to the line
- (m) length of line in Km
- (n) the way in which Services is offered

5.2 The Requesting Party shall keep updated a database consisting of all active and ordered Terminating Segment of the Leased Line. The database shall contain all necessary information that will allow both Parties to reconcile accounts for charging purposes.

IAK

Handwritten initials: *AK*, *Mz L.B*, *YZ*

## 6 Ordering and Delivery

- 6.1 Ordering and delivery is handled according to Annex H in additional to the following Clauses.
- 6.2 The Requesting Party shall request the Wholesale Terminating Segment of the Leased Line of those Customers who are connected to Omantel Network.
- 6.3 Omantel shall target a delivery time of 30 Working Days subject to feasibility, cooperation of the Requesting Party and any other third Party. These delivery dates are subject to feasibility, cooperation of the Requesting Party and any other third Party and that there will be no delays caused by factors outside Omantel's control such as, for example, due to the delay arising from the involvement of governmental entities.
- 6.4 The Requesting Party may only request the Service once every week on a week day agreed between both Parties. Both Parties agree on the number of connections that can be submitted at a time.
- 6.5 Omantel technician jointly with the Requesting Party's technician shall connect and test the Service,
- 6.6 The Requesting Party's network should be ready with the Services provisioning to the Customer to before Omantel and the Requesting Party teams jointly connect the Customer. This will ease testing the Services.
- 6.7 If Omantel rejects the Requesting Party request, Omantel shall inform the Requesting Party on the reasons, which shall be objectively justifiable such as technical feasibility problems.

IAK

AKP Mz L.B 42

Access and Interconnection Agreement – Omantel – Ooredoo

Sub Annex C-FA 10 \_ Wholesale Terminating Segment of Leased Line

## 7 Prices

- 7.1 The up to date prices for the Services can be found in Annex M.
- 7.2 The cost of additional product features, specialized billing, systems and/or network interfaces, non-standard connectivity and associated configuration, integration and testing are not included in the published tariffs. Such cases will be dealt with on a case-by-case basis against mutual agreed timelines and charges. Omantel shall inform the TRA accordingly, and obtain the necessary approvals from it.

IAK

AKP Mz L.B 42

Page 12 of 14

Access and Interconnection Agreement – Omantel – Ooredoo

Sub Annex C-FA 10 \_ Wholesale Terminating Segment of Leased Line

## 8 Fault Management

- 8.1 Fault Management shall be handled according to Annex H in additional to the following Clauses.
- 8.2 The Requesting Party shall ensure to carry out the initial tests in respect of any fault in Customer connection in order to validate that the fault is not from the Requesting Party Network. In case the fault is not at the Requesting Party Network, the Requesting Party shall make available all reasonable and complete test details when reporting the fault to Omantel.
- 8.3 In case no Fault found from Omantel's side, the Requesting Party shall compensate Omantel the reasonable incurred cost of fault reporting, which it shall be able to substantiate on request.

IAK  
Aly Mz L.B 42

Page 13 of 14

Access and Interconnection Agreement – Omantel – Ooredoo

Sub Annex C-FA 10 \_ Wholesale Terminating Segment of Leased Line

## 9 Forecasts

9.1 Forecasting shall be handled according to Annex F.

IAK

AK Mz L.B 42

Page 14 of 14