

**ANNEX C**  
**ANCILLARY SERVICES**

Annex C.1  
**SPECIAL SERVICES**

# Index

<b><u>INDEX</u></b> .....	<b>3</b>
<b>1 <u>GENERAL</u></b> .....	<b>4</b>
<b>2 <u>ACCESS TO TOLL FREE NUMBERS</u></b> .....	<b>5</b>

## 1. General

- 1.1 This Sub Annex sets out the special services for the Ooredoo Network to which Ooredoo shall offer access to and the charges which Ooredoo shall apply for relation to such access.
- 1.2 Ooredoo shall accept at a Point of Interconnection between the Parties Networks and convey Calls in accordance with this Agreement and technical annexes, including Call set-up and clear-down sequences.
- 1.3 Ooredoo shall convey Calls during those periods of time and at the same standard and quality of service as Ooredoo conveys similar Calls to its customers.
- 1.4 Ooredoo Fixed shall accept and terminate all Calls to services contained in this Sub-Annex to numbers that form part of its number ranges as allocated by the TRA.
- 1.5 Both Parties shall correct faults that occur in their respective Networks which affect the conveyance of Calls in accordance with the Agreement where such faults affect directly or indirectly affect Traffic crossing a Point of Interconnection between the Parties' Network. For the avoidance of doubt, neither Party warrants that its Network is, or will be, free from faults.
- 1.6 Ooredoo shall accept and convey CLI information at Points of Interconnection as provided for in this Agreement.

## 2. Access to Toll Free Numbers

- 2.1 Ooredoo shall offer to the Access Seeker, upon request, access to one or more Call services provided by customers of the Operators over the Operator's network through the use of a "Toll Free Number". For each Call by end users of the Access Seeker's network to the Operator's "Toll Free Numbers", the Operator will pay Access Seeker the termination charge according to Annex B-1. The Access Seeker is not entitled to charge its end users for Calls to the Operator's "Toll Free Numbers".

**Annex C.2**  
**PORT CAPACITY**

# Index

<b>INDEX</b> .....	7
<b>1 GENERAL</b> .....	8
<b>2 DEFINITIONS</b> .....	9
<b>3 PORT CAPACITY ORDERING</b> .....	10
<b>4 PORT CAPACITY ORDER DELIVERY TIME</b> .....	11
<b>5 REMOVAL OF PORT CAPACITY</b> .....	12
<b>6 ORDER AMENDMENT</b> .....	13
<b>7 PRICES</b> .....	14

# 1. General

This Sub Annex sets out Ooredoo's Port Capacity Services used at a Point of Interconnection.



## 2. Definitions

- 2.1 The definitions in Annex A of the Agreement shall apply to this Sub-Annex C.2 in addition to the following definitions:
- 2.1.1 Port Capacity – The number of 2Mbit/s switch ports at a Point of Interconnection;
  - 2.1.2 Port Capacity Order - An order for 2Mbit/s port capacity at a Point of Interconnection submitted by one Party to the other Party.

# 3. Port Capacity Ordering

3.1 Port capacity ordering and delivery are to be fulfilled according to the procedures set out in the Main Body of the Agreement.

3.2 When requesting port capacity, the Access Seeker shall comply with the basic cabling and wiring criteria during installation as agreed with Ooredoo for:

3.2.1 Frame Blocks

- i) 2Mbit/s (120 Ohm termination) a balanced termination block with break and test facilities are provided as part of the DDF (Digital Distribution Frame)
- ii) All cables types and specification shall be approved by Ooredoo.
- iii) Arrangement of cables shall be properly managed and labelled.
- iv) All cables shall be securely fastened by cable clamps within the rack.

3.2.2 In-Building Wiring

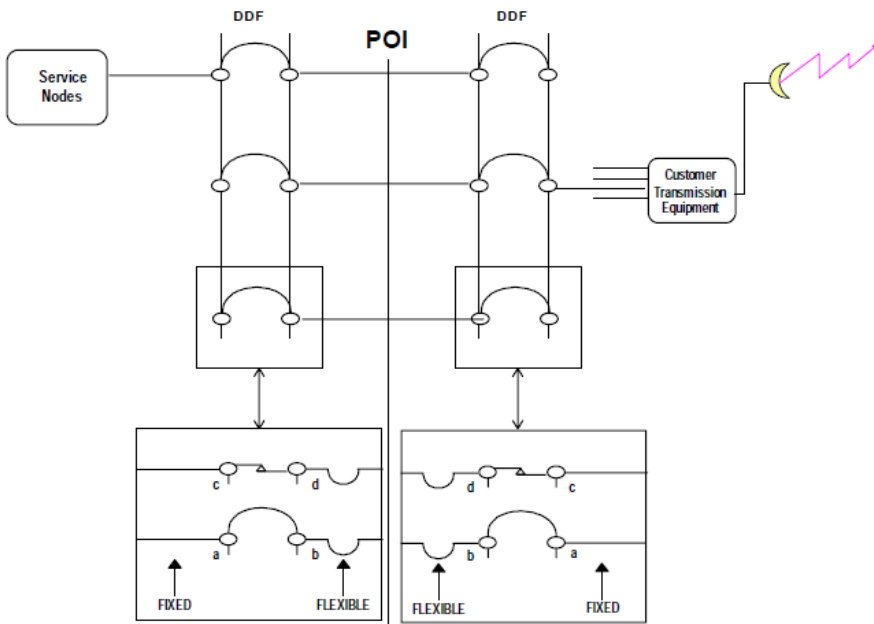

Figure 1: Collocated Interconnection

## 4. Port Capacity Order Delivery Time

- 4.1 With respect to Port Capacity ordered at a Point of Interconnection already in operation, Ooredoo shall have a target delivery time of –25-70 Working Days following the date of receipt of the relevant Port Capacity Order. For the avoidance of doubt Port Capacity includes Distribution Block allocation and jumpering. Basic block and expansion co-location shall have a delivery time of 30 – 60 Working Days.
- 4.2 Port Capacity ordered at Point of Interconnection that is not already in operation shall have a target delivery time of up to 90 Working Days.
- 4.3 These delivery dates are subject to the Requesting Party having fully cooperated with Ooredoo and that there will be no delays caused by factors outside Ooredoo's control such as, for example, due to the delay arising from the involvement of governmental entities.
- 4.4 If testing is considered necessary by one Party such testing shall be fulfilled in accordance with test specifications contained in this Agreement.
- 4.5 The Parties shall use reasonable endeavours to complete such testing in the shortest appropriate time (no more than 10 days). Ooredoo shall provide Access Seeker with reasonable time to prepare for the testing before commencing the testing. The Parties shall co-operate to ensure that testing is reasonably spread across the agreed testing period.
- 4.6 As soon as the Port Capacity is ready for service, both Parties shall in writing or via e-mail certify that the Port Capacity Order has been satisfactory delivered.

## 5. Removal of Port Capacity

- 5.1 Other than for reasons of payment default by The Access Seeker or as otherwise provided for under the terms of this Agreement, once installed, Port Capacity can only be terminated by Ooredoo with the written consent of the Access Seeker paying for the service.
- 5.2 Access Seeker may terminate any Port Capacity at any POI upon twelve (12) weeks written notice to Ooredoo. Notice for removal of Port Capacity may also be effected through forecasting. The notice should be sent to the Ooredoo position responsible for network design and ordering as stated in Annex D.

## 6. Order Amendment

Port Capacity Orders may not be amended unless the Parties agree to do so in writing or where the Requesting Party pays for any reasonable costs incurred by the variation and which Ooredoo shall substantiate on request.

## 7. Prices

- 7.1 The charges for the Port Capacity are outlined in Annex F – Pricing.
- 7.2 Invoices in the amounts stated or multiples thereof as may be appropriate against quantities specified in orders shall be issued by Ooredoo on each instance acceptance of such orders. Invoicing shall be monthly in advance. Invoices shall be payable within 30 days.

**Annex C.3**

**IMPLEMENTATION OF NUMBER RANGES**

# Index

<b>INDEX</b> .....	<b>16</b>
<b>1</b> <b><u>GENERAL</u></b> .....	<b>17</b>
<b>2</b> <b><u>NUMBER IMPLEMENTATION SERVICE</u></b> .....	<b>18</b>
<b>3</b> <b><u>CHARGES &amp; DELIVERY TIMES FOR NUMBER IMPLEMENTATION</u></b> .....	<b>19</b>



# 1. General

- 1.1 Ooredoo delivers services to implement numbers in the Ooredoo Network. The services are charged and delivered according to the conditions stated in this Sub-Annex.
- 1.2 Ooredoo will only accept orders concerning number ranges that are allocated to the Access Seeker, according to the National Numbering Plan published by the TRA.

## 2. Number Implementation Service

- 2.1 Ooredoo offers a service of Number Implementation, that is, implementation of other parties' number ranges in the Ooredoo Network for the purposes of call routing. Ranges implemented may consist of complete or partial new number ranges or may be defined by any type of complete or partial variation of an existing number range or ranges previously implemented in the Ooredoo Network.
- 2.2 Ooredoo will only accept and implement orders concerning number ranges that are allocated to the seeking party (the "Access Seeker") same, according to the National Numbering Plan published by the TRA.
- 2.3 Ooredoo will invoice the Access Seeker according to the quantity and type or types of number contained in each order.

## 3. Charges & Delivery Times for Number Implementation

3.1 The following charges and delivery times shall apply for Number Implementation Services.

Table 1

Type of Number	Charges	Ooredoo Delivery Time from written Order acceptance
Fixed Network	As per Annex F - Pricing	22 Working Days
Toll-free number		22 Working Days
Mobile phone numbers (MSISDN)		22 Working Days
Premium rate numbers		22 Working Days
Other numbers		22 Working Days

**Annex C.4**

**POINT OF INTERCONNECTION**

# Index

<b>INDEX</b> .....	<b>21</b>
<b>1</b> <b><u>GENERAL</u></b> .....	<b>22</b>
<b>2</b> <b><u>POINTS OF INTERCONNECTION</u></b> .....	<b>23</b>
<b>3</b> <b><u>ORDERING OF POINTS OF INTERCONNECTION</u></b> .....	<b>25</b>
<b>4</b> <b><u>CHARGES FOR POINTS OF INTERCONNECTION</u></b> .....	<b>26</b>

# 1. General

This Sub Annex sets out the Points of Interconnection of Ooredoo's network.

## 2. Points of Interconnection

### 2.1 Ooredoo Fixed Primary Level

Ooredoo Primary Switches are shown in Table 1 below for both National and International traffic.

Table 1

No	Region	Location	Type	Code
	Sohar	Sohar	Huawei	2-2254
	Muscat	Bousher	Huawei	

Note: Ooredoo will have 2 switches, one in Sohar another in Bousher, using the same Dual homed SoftSwitch.

2.2 Ooredoo offers the establishment of Points of Interconnection at each of the international switches set out in Table 1, each of which allows the transit over Ooredoo network of calls which originate from networks within Oman and terminate in networks outside Oman, and vice versa.

### 2.3 Ooredoo Mobile

Ooredoo shall deploy Mobile Switching Centers (“MSCs”) as follows:

Table 2

Location	Type	Code	National Point Code
Muscat 1	Ericsson	MSC 1	2-1225
Muscat 2	Ericsson	MSC 2	2-1235
Nizwa1	Ericsson	MSC 3	2-2761
Nizwa 2	Ericsson	MSC 4	2-1737
Sohar 1	Ericsson	MSC 5	2-2251

2.4 Ooredoo offers the establishment of Points of Interconnection at each of the Interconnection switches set out in Table 2, each of which allows the set-up of Mobile calls.

### 2.5 Signaling

The Parties shall use the signaling protocol Signaling System No.7 for the purposes of interconnection between their networks, in accordance with relevant ITU-T and ETSI standards

and recommendations of Ooredoo and Access Seeker signalling system are based on ITU-T White Book and ETSI Version2.

2.6 Ooredoo shall deploy Signaling Transfer Points (“STPs”) as follows:

Table 3

<b>Location</b>	<b>Type</b>	<b>Code</b>	<b>National Point Code</b>
Muscat 1	Ericsson	GMSC	2-1225
Nizwa 1	Ericsson	GMSC	2-2761
Nizwa 2	Ericsson	GMSC	2-2251

2.7 Ooredoo shall provide the following 2 Mbit/s interconnect links, for both its fixed and mobile network:

2.7.1 In-building Interconnect (IBI);

2.7.2 Customer Sited Interconnect (CSI); and

2.7.3 In-Span Interconnect (ISI).

All Access and Interconnect Services shall be carried over these forms of Interconnect Links and any physical interconnect paths shall be constructed by mutual agreement when used for both parties' services.



## **3. Ordering of Points of Interconnection**

3.1 Points of Interconnection (“Pol's”) will be ordered in accordance with the ordering and delivery provisions of the Main Body of this Agreement. Delivery of POIs takes 34-75 days.

## 4. Charges for Points of Interconnection

- 4.1 For each Point of Interconnection (“PoI”) the ordering party shall pay the other party an establishment fee as defined in Annex F - Pricing. For the avoidance of doubt, the Parties agree that the rental charge is not substitutive of any element of the charge for establishment referenced below. In each instance, the rental charge for the first year shall be invoiced on placement of order and shall be payable within 30 days. Rental charges for following years shall be invoiced on each annual anniversary of order, and shall become due for payment within 30 days.